

JOYSTICK WITH GRIP OPTIONS

HJMG3
JOYSTICK
WITH GRIP

UP TO 5 MILLION OPERATIONAL CYCLES IN ALL DIRECTIONS



HJMG3-A

HJMG3-B

HJMG3-C

HJMG3-CK

HJMG3-D

HJMG3-M

Integrated HJMG3 joystick and grip assemblies combine a medium, top-mount, JHM Hall effect joystick with a grip. These models serve agriculture, construction, material handling, and specialized industrial and heavy equipment applications.

Joystick and grip assemblies:

HJMG3-A comes with a smaller G3-A Universal Grip

HJMG3-B comes with a larger G3-B Universal Grip

HJMG3-C comes with a medium G3-C Universal Grip

HJMG3-CK comes with a medium G3-CK Universal Grip

HJMG3-D comes with a G3-D Control Grip

HJMG3-M comes with a medium G3-M Universal Grip

The HJMG3 can be configured with high switch content for top-of-the-line machinery or with only basic functions. Choose from CANopen, J1939, PWM, USB or analog outputs and several gating options. (CAN, PWM and USB outputs are not available with the HJMG3-CK model.)

Refer to the JHM joystick catalog pages for additional handles with options for pushbuttons, rockers and keypads.

Features:

- Select from dozens of standard faceplates or customize with a wide selection of switches
- Field-replaceable faceplates or grips available on select models*
- Armrest or panel mounted
- Joystick mechanical life up to 5 million cycles
- CANopen, CANbus J1939, analog, PWM and USB outputs
- Single output Z-axis option for G3-A and G3-B grips; single and redundant Z-axis options with G3-C grip
- Electronics sealed to IP68S
- Custom termination and mounting options
- RoHS compliant

**Contact factory for field-replaceable option information.*



LONG LIFE, HALL EFFECT TECHNOLOGY JOYSTICK

Standard Characteristics/Ratings:				
ELECTRICAL: Output options AA-FT and LL				
Joystick				
Rated at Vcc = 5V @ 20°C	Units	Min	Typ	Max
Load = 1 ma (4.7 KΩ)				
Supply Voltage, Vcc	VDC	4.5	5.0	5.5
Output Voltage Tolerance at Center AA and DD	VDC @ 5V Vcc	-.25	N/A	+.25
Output Voltage Tolerance at Center AT and DT	VDC @ 5V Vcc	-.15	N/A	+.15
Output Voltage Tolerance at Full Travel	VDC @ 5V Vcc	-.25	N/A	+.25
Supply Current Per Sensor B=0, Vcc=5V, Iout=0	mA	N/A	N/A	10
Output Source Current Limit B=X*, Vo=0	mA	-1.20	N/A	1.20
PWM Joystick				
Supply Voltage, Vcc	VDC	4.5	5.0	5.5
Output Frequency	Hz	425	500	575
Amplitude Low @ 5mA	VDC	N/A	0.5	NA
Amplitude High - Pullup Required	VDC	4.5	5.0	5.5
PWM Output @ +X and +Y Full Travel	%	80.0	90.0	92.0
PWM Output @ Zero Travel	%	42.0	50.0	58.0
PWM Output @ -X and -Y Full Travel	%	8.0	10.0	20.0
P9 Switches				
Electrical Rating	10mA Resistive Load @ 5VDC			
Electrical Life	1,250,000 Cycles			
HTW Switches				
Supply Voltage, Vcc	VDC	4.5	5.0	5.5
Output Voltage Tolerance at Center	VDC @ 5V Vcc	-.15	NA	+.15
Output Voltage Tolerance at Full Travel	VDC @ 5V Vcc	-.25	N/A	+.25
Supply Current B=0, Vcc=5V, Iout=0	mA	N/A	N/A	10
HTWM and HRTL4 Switches				
Supply Voltage, Vcc	VDC	4.50	5.00	5.50
Output Voltage Tolerance at Center	VDC @ 5V Vcc	-.25	NA	+.25
Output Voltage Tolerance at Full Travel	VDC @ 5V Vcc	-.25	N/A	+.25
HTWM Supply Current B=0, Vcc=5V, Iout=0	mA	N/A	N/A	10
HRTL4 Supply Current B=0, Vcc=5V, Iout=0	mA	N/A	10	12
HTWS Switches				
Supply Voltage	VDC	4.50	5.00	5.50
Output Voltage Tolerance at Center	VDC @ 5V Vcc	-.25	N/A	+.25
Output Voltage Tolerance at Full Travel	VDC @ 5V Vcc	-.25	N/A	+.25
Supply Current per Die B=0, Vcc=5V, Iout=0	mA	N/A	N/A	10
K1S Switches				
Electrical Rating	10 mA Resistive Load @5VDC			
Electrical Life	1,000,000 Cycles			
TC-5 Switches				
Electrical Rating @ 1-32 VDC	10-100mA			
Electrical Life	3,000,000 Cycles			
Keypad				
Circuit Configuration	SPST N.O.			
Voltage	1-32 VDC			
Current	10-100 mA Resistive			
MECHANICAL:				
Joystick				
Mechanical Life	5,000,000 cycles; 250,000 cycles (Friction)			
Travel Angle	Degrees	18	20	22

Standard Characteristics/Ratings:				
Op. Force (w/Boot) High Force @ GRP, Return to Center	Lbs.	1.5	2.5	3.5
Op. Force (w/Boot) Medium Force @ GRP, Return to Center	Lbs.	1.0	2.0	3.0
Op. Force (w/Boot) High Force @ GRP, Friction	Lbs.	1.0	2.5	4.0
P9 Switches				
Mechanical Life	1,250,000 cycles			
Operating Force	Oz.	1.2	1.7	2.2
HTW and HTWM Switches				
Mechanical Life Full Forward to Full Back Travel Angle	3,000,000 cycles +/- 40°			
Operating Force 25°C at Top of Roller	Oz.	2	5	8
Maximum Allowable Radial Load	Lbs.	N/A	N/A	30
HRTL4 Switches				
Mechanical Life	3,000,000 cycles			
Travel Angle	Degrees	19	20	21
Operating Force (w/Boot) at Top of Button, @ 20° C	Oz.	5	8	16
Max Allowable Vertical Force on Button	Lbs.	N/A	N/A	25
Max Allowable Radial Force on Top of Knob	Lbs.	N/A	N/A	25
Max Allowable Torque on Button About Shaft Axis	In-Lbs.	N/A	N/A	5.5
K1S Switches				
Mechanical Life	1,000,000 cycles			
TC-5 Switches				
Mechanical Life	3,000,000 cycles			
Operating Force	Oz.	8	16	24
Keypad				
Mechanical Life	3,000,000 Min. Cycles.			
ENVIRONMENTAL				
Joystick				
	Units	Min	Typ	Max
Operating Temperature	°C	-40	20	85
Electrical Enclosure Design Output Styles: AA, DD, AT, DT, LL	ISO 20653, IP68S, Dust tight, continuous immersion 1 meter for 31 minutes, stationary during test			
Electrical Enclosure Design Output Styles: JJ, KK	ISO 20653, IP64S, Dust tight, water jets stationary during test			
Electrical Enclosure Design Output Styles: MM, NN	Unsealed			
EMI/RFI Withstand	Per SAE J1113. Contact factory for details.			
P9 Switches				
Enclosure Design	Sealed to IP68S			
HTW Switches				
Electronics Seal Integrity	IP68S			
HTWM Switches				
Electronics Seal Integrity	IP68S			
Mechanical Seal Integrity	Unsealed			
HTWS Switches				
Operating Temperature	°C	-40	20	85
Electrical Enclosure Design	IP68S			
HRTL4 Switches				
Electronics Seal Integrity	IP68S			
K1S Switches				
Operating Temperature	°C	-40	20	85
Electronics Seal Integrity	IP68S			
TC-5 Switches				
Electronics Seal Integrity	IP68S			
Keypad				
Operating Temperature	°C	-40	20	85
Faceplate Keypad Enclosure	IP68S			

JOYSTICK WITH GRIP OPTIONS

HJMG3
JOYSTICK
WITH GRIP

UP TO 5 MILLION OPERATIONAL CYCLES IN ALL DIRECTIONS

Standard Characteristics/Ratings:

Side Keypad Enclosure	IP68S
Grip	
Seal Integrity	Unsealed
MATERIAL:	
Plunger	Stainless Steel with Insert
Handle	Thermoplastic, Glass Reinforced, Black
Faceplate	Thermoplastic, Glass Reinforced, Black
Mounting Screws	4X #10-32 Screws (Shipped Unassembled) Maximum Torque = 25IN-LBS
Wires (Output Options AA-DT and LL)	24 AWG, (19 Strands of 36 AWG) per SAE AS22759
Side Keypad Wires	24 AWG, (26/.10TA) Insulation Diameter: .037 Insulation Type: PVC (40 in. from bottom of joystick) Mounting Hardware #10-24 x 3/4 Carriage Bolts Self Locking Nuts
Cable (Output Options JJ and KK)	22 AWG (19 Strands of 34 AWG)

HJMG3 SUGGESTED PANEL OPENING

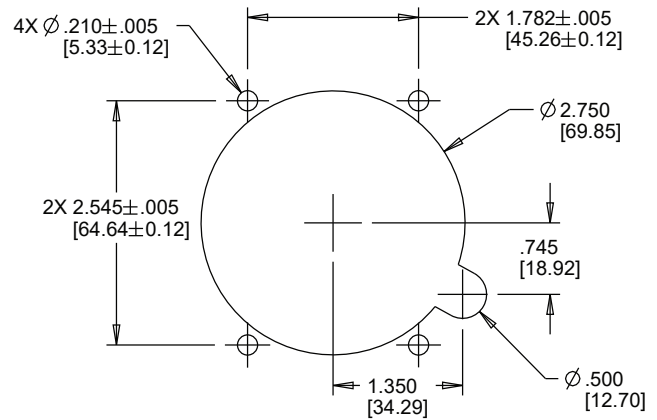

SUGGESTED PANEL OPENING
MAX. PANEL THICKNESS = 0.15 INCHES

OUTPUTS AA & AT AND DD & DT

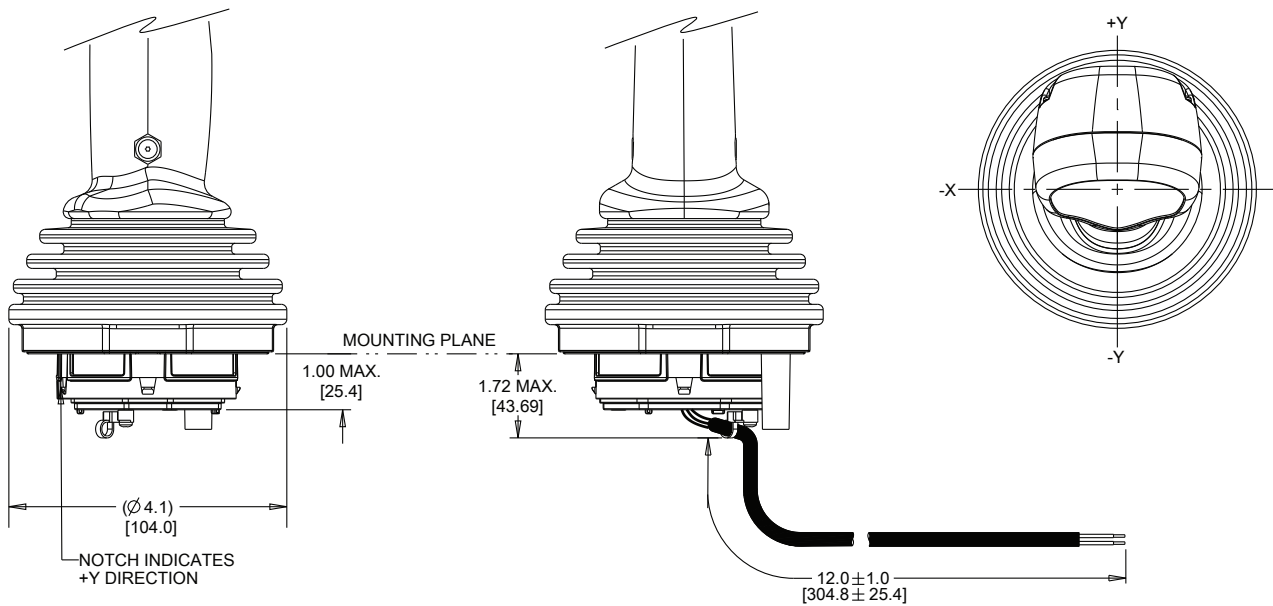

Wires and strain relief not shown in all views for clarity.

Unless otherwise specified, all dimensions are in inch [metric]. In the event of a conflict, the inch nominal value and tolerance will take precedence.

LONG LIFE, HALL EFFECT TECHNOLOGY JOYSTICK

OUTPUTS JJ AND KK

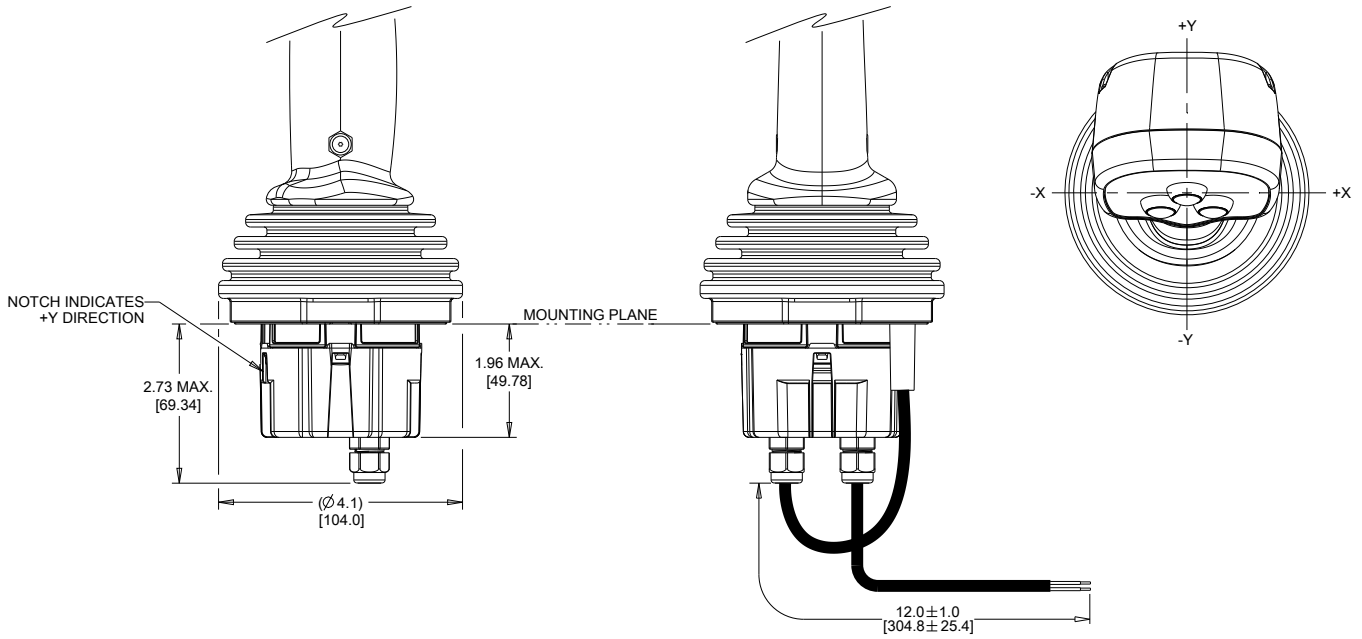

OUTPUTS MM AND NN

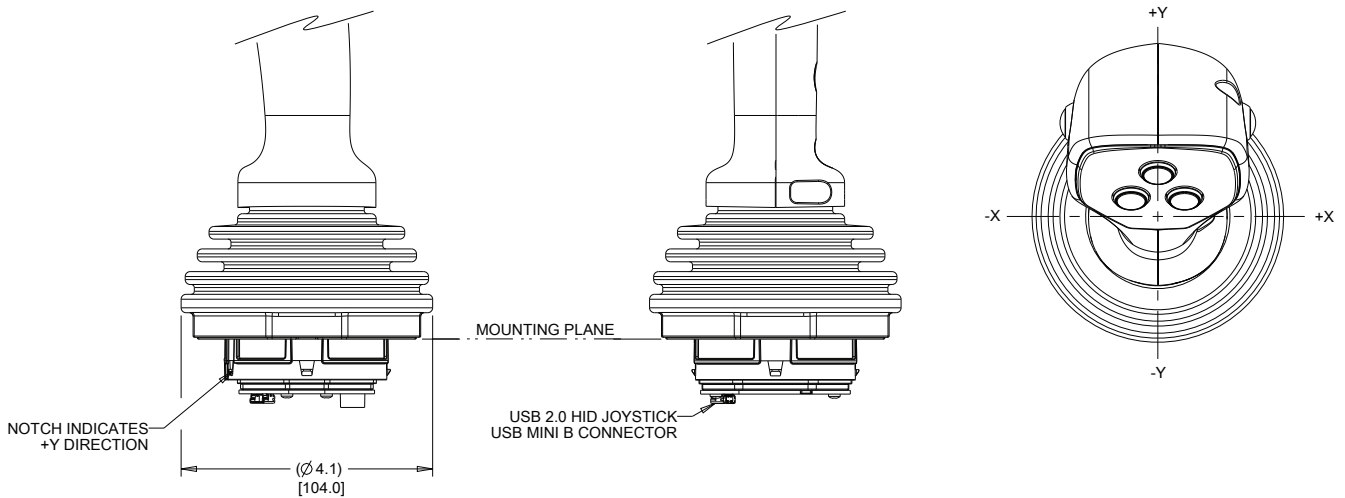

Wires and strain relief not shown in all views for clarity.

Unless otherwise specified, all dimensions are in inch [metric]. In the event of a conflict, the inch nominal value and tolerance will take precedence.

JOYSTICK WITH GRIP OPTIONS

HJMG3
JOYSTICK
WITH GRIP

UP TO 5 MILLION OPERATIONAL CYCLES IN ALL DIRECTIONS

HJMG3 OUTPUTS

OPTION AA & AT

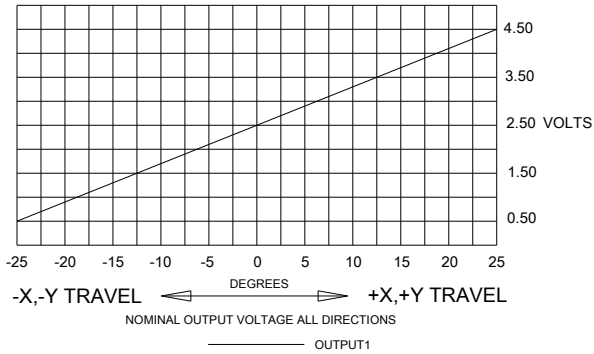

OPTION DD & DT

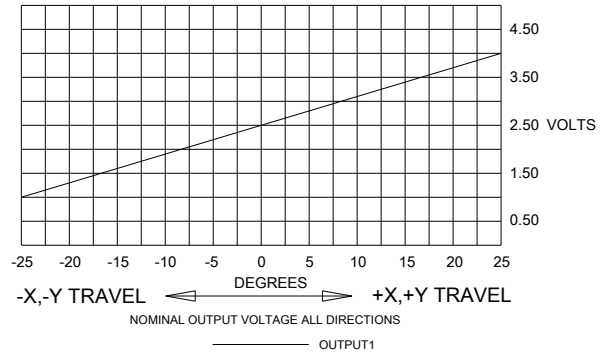

OPTION LL

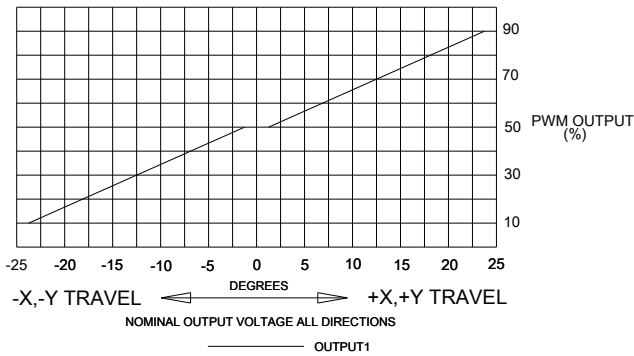

HHLT4 OUTPUT

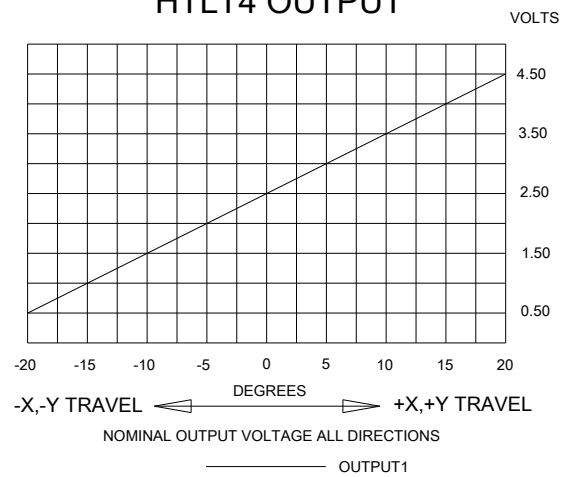

HTW & HTWM OUTPUT

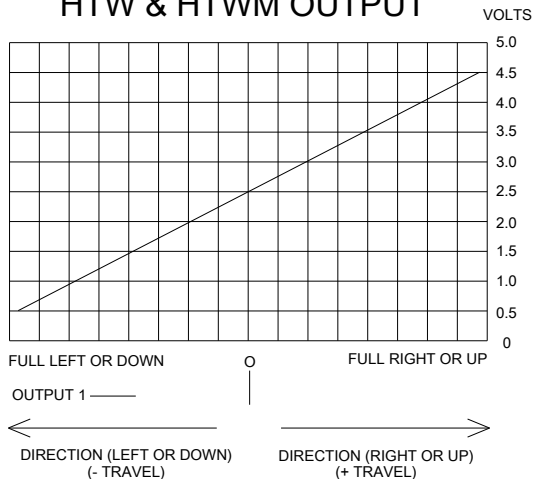

HTWS OUTPUT

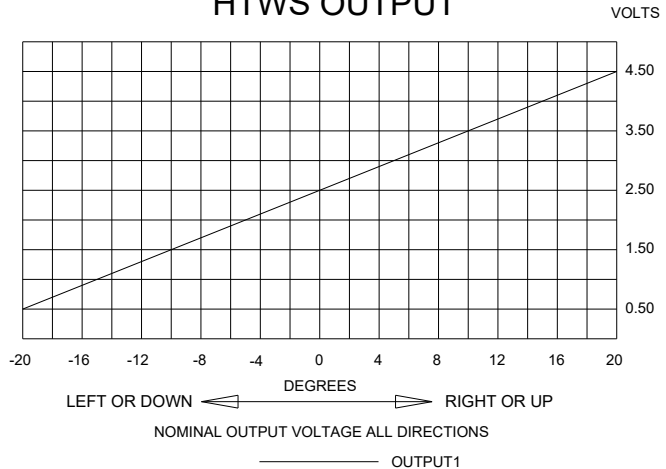

HALL EFFECT CONTROLS

JOYSTICK WITH GRIP OPTIONS

UP TO 5 MILLION OPERATIONAL CYCLES IN ALL DIRECTIONS

The HJMG3-B combines a large G3-B Universal Grip with a top-mount JHM Hall effect joystick base. The grip offers a choice of 11 standard faceplates with a combination of pushbuttons, rockers and thumbwheels. A trigger pushbutton on the back of the grip handle is optional.

Visit the G3-B product page for more information about the grip, which is customizable to customer specifications.

HJMG3-B



HJMG3-B DRAWINGS

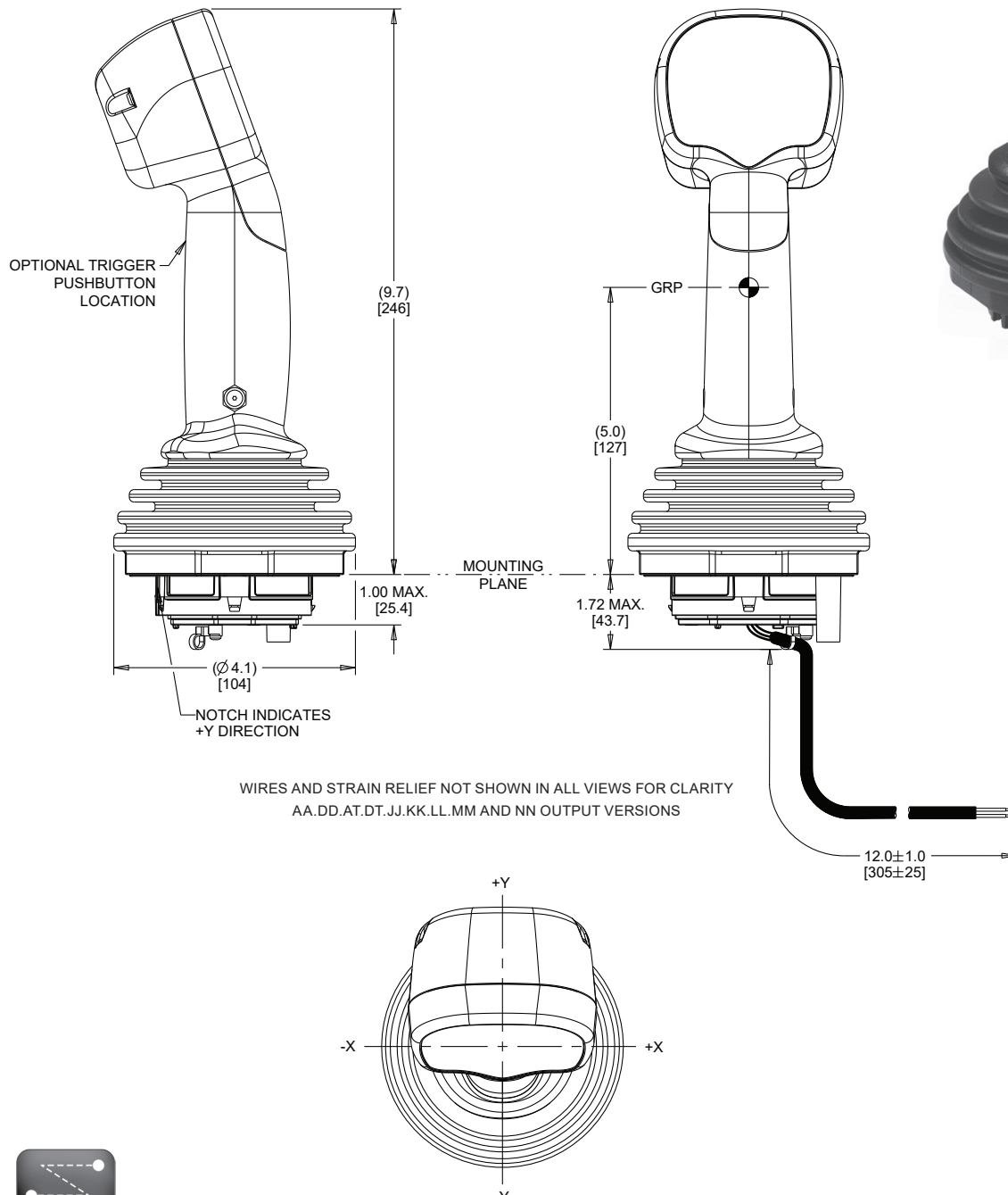

LONG LIFE, HALL EFFECT TECHNOLOGY JOYSTICK

HJMG3-B PART NUMBER CODE

HJMG3 - X	XX	X	B	XX	X	X	X
Gating*	Output**	Force	Faceplate	Trigger Pushbutton Color	P9 Button Grip Head (Black)	P9 Button Color (Faceplate)	
1. Gated Single Axis; Return to Center	AA. 2.5 +/- 2.0 VDC DD. 2.5 +/- 1.5 VDC	1. Medium 2. High	BA BB BF BG BH BJ BK BL	1. None 2. Black 3. Red	1. None	N. None 1. Red 2. Black 3. Orange 4. Yellow 5. Green 6. Blue 7. Violet 8. Gray 9. White	
3. Omni-directional; Round Smooth Feel	AT. 2.5 +/- 2.0 VDC ① DT. 2.5 +/- 1.5 VDC ①						
5. Omni-directional; Round On-Axis Guided Feel	JJ. CANbus J1939 KK. CANopen						
6. Friction – Single Axis	LL. PWM						
7. Friction Y-Axis; Return-to-Center X-Axis	MM. USB-Inverted Y ② NN. USB-Standard Y ②						
8. Omni-directional; Square Smooth Feel							
9. Omni-directional; Square On-Axis Guided Feel							

*Gating Options 6 and 7 only available with Force Option 2

**Outputs are from the center to the full travel position in each direction. Options "AA", "DD", "AT", "DT" provide increased voltage in +X, +Y; and decreasing voltage in -X, -Y for output.

① Options "AT" and "DT" are identical to options "AA" and "DD" respectively except with a tighter center tolerance.

② For outputs "MM" and "NN", the reported values for the X-direction increase as the joystick moves from left to right. For output "MM" (Inverted Y), the reported values for the Y-direction decrease as the joystick moves from far to near. For output "NN" (Standard Y), the reported values for the Y-direction increase as the joystick moves from far to near.

HJMG3-B GATING ICONS

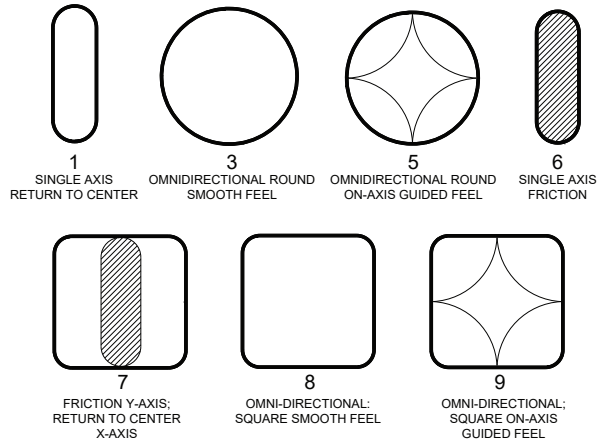

HJMG3 SUGGESTED PANEL OPENING

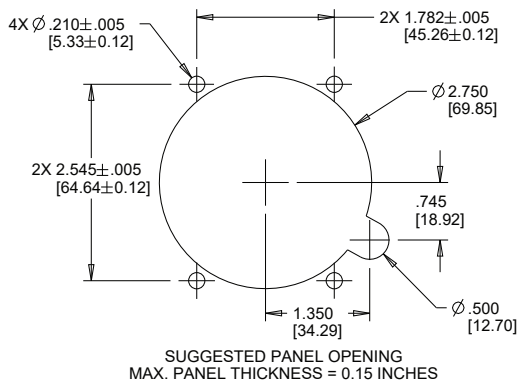

JOYSTICK WITH GRIP OPTIONS

HJMG3-B
JOYSTICK
WITH GRIP

UP TO 5 MILLION OPERATIONAL CYCLES IN ALL DIRECTIONS

HJMG3-B FACEPLATES AND SCHEMATICS

